

1 PLAN
Scale: 1/4"=1'-0"

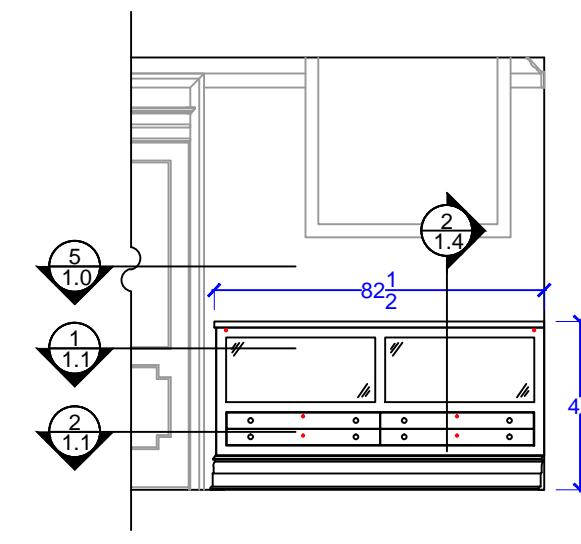

2 ELEVATION
Scale: 1/4"=1'-0"

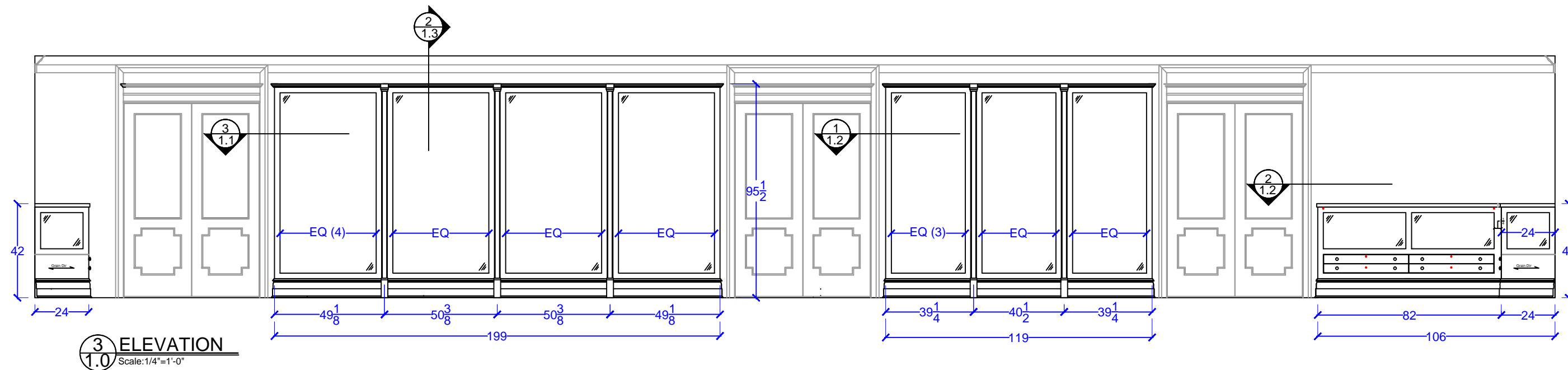

3 ELEVATION
Scale: 1/4"=1'-0"

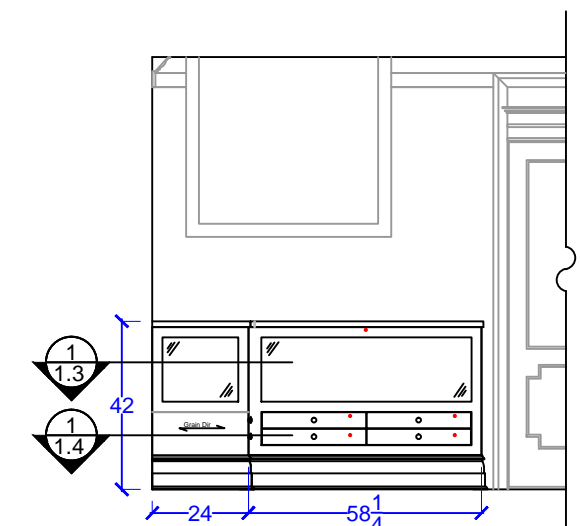

4 ELEVATION
Scale: 1/4"=1'-0"

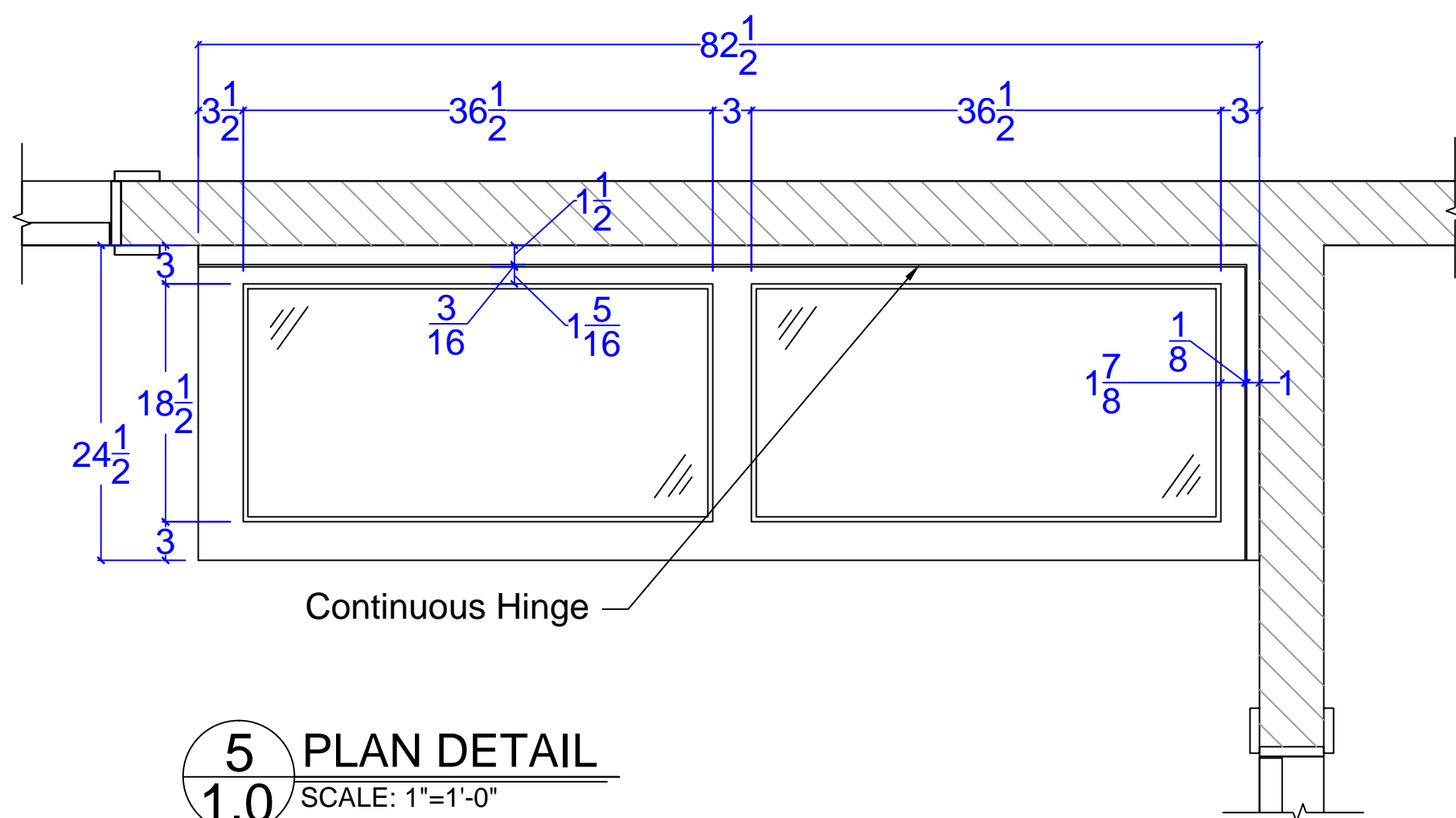

5 PLAN DETAIL
SCALE: 1"=1'-0"

NOTES, MATERIALS and SPECIFICATIONS:

- Cabinet Interiors/Exteriors: Red Oak, Solid and Veneer
- 3/4" Oak Veneered Slatwall Backs w/Metal Inserts(Oil Rubbed Bronze)
- Drawer Boxes: Solid Maple, Dovetailed
- Drawer Slides: Side Mount, Full Extension Ball-bearing
- Knobs, Pulls: TBD
- Hinges: 3" Non-Mortise Hinges- Black
- 1/4" Tempered UV Filtered Glass-TYP
- CompX Timberline Thick Panel Cam Lock Type 170 at Tall Case Doors
- CompX Timberline Type 280 Locks at Drawers
- CompX Timberline Type 181 Locks at Hinged Case Lids

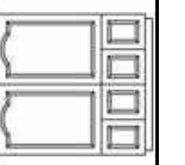

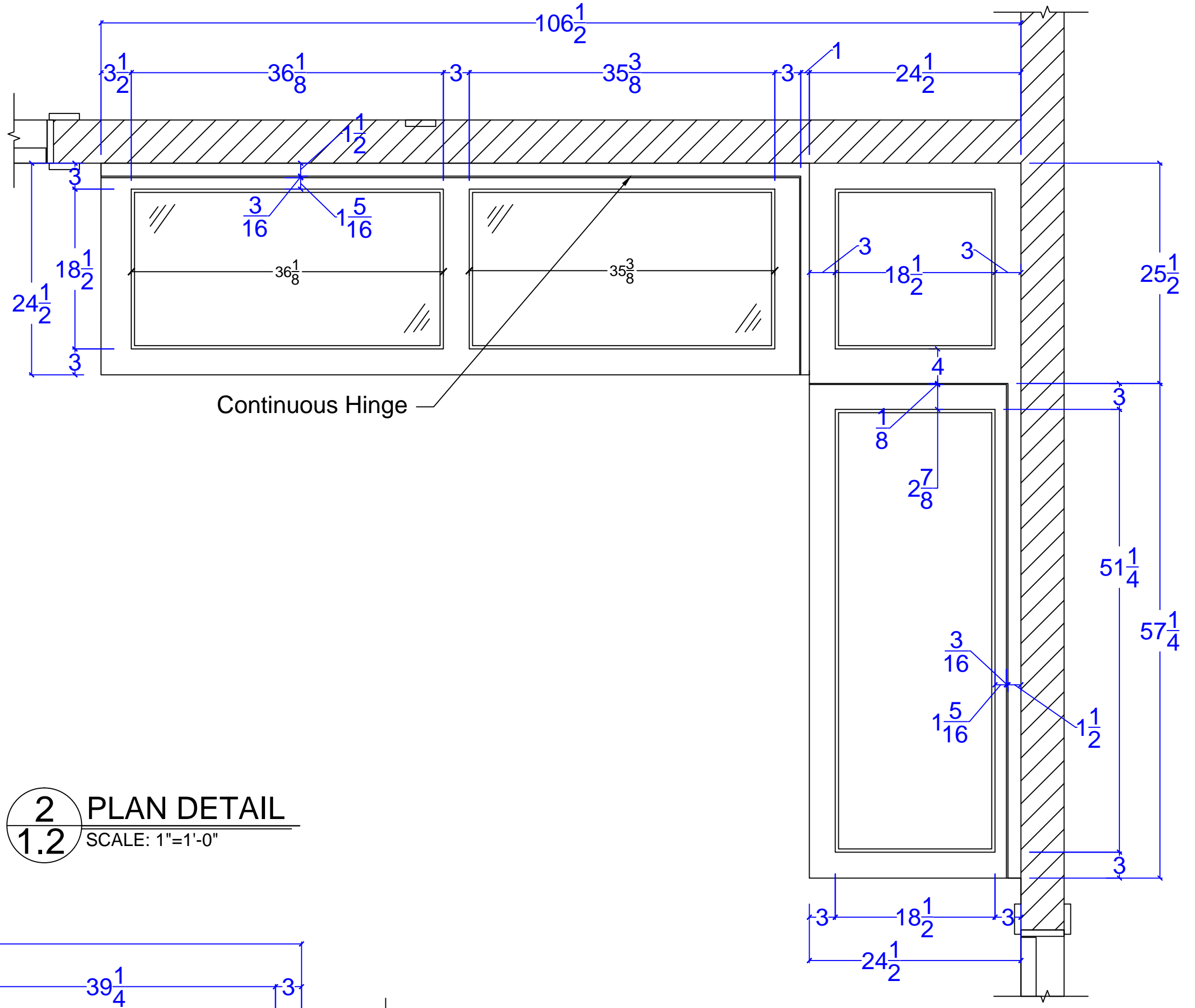
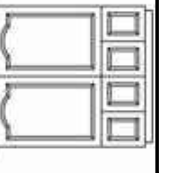

2 PLAN DETAIL
 1.2 SCALE: 1"=1'-0"

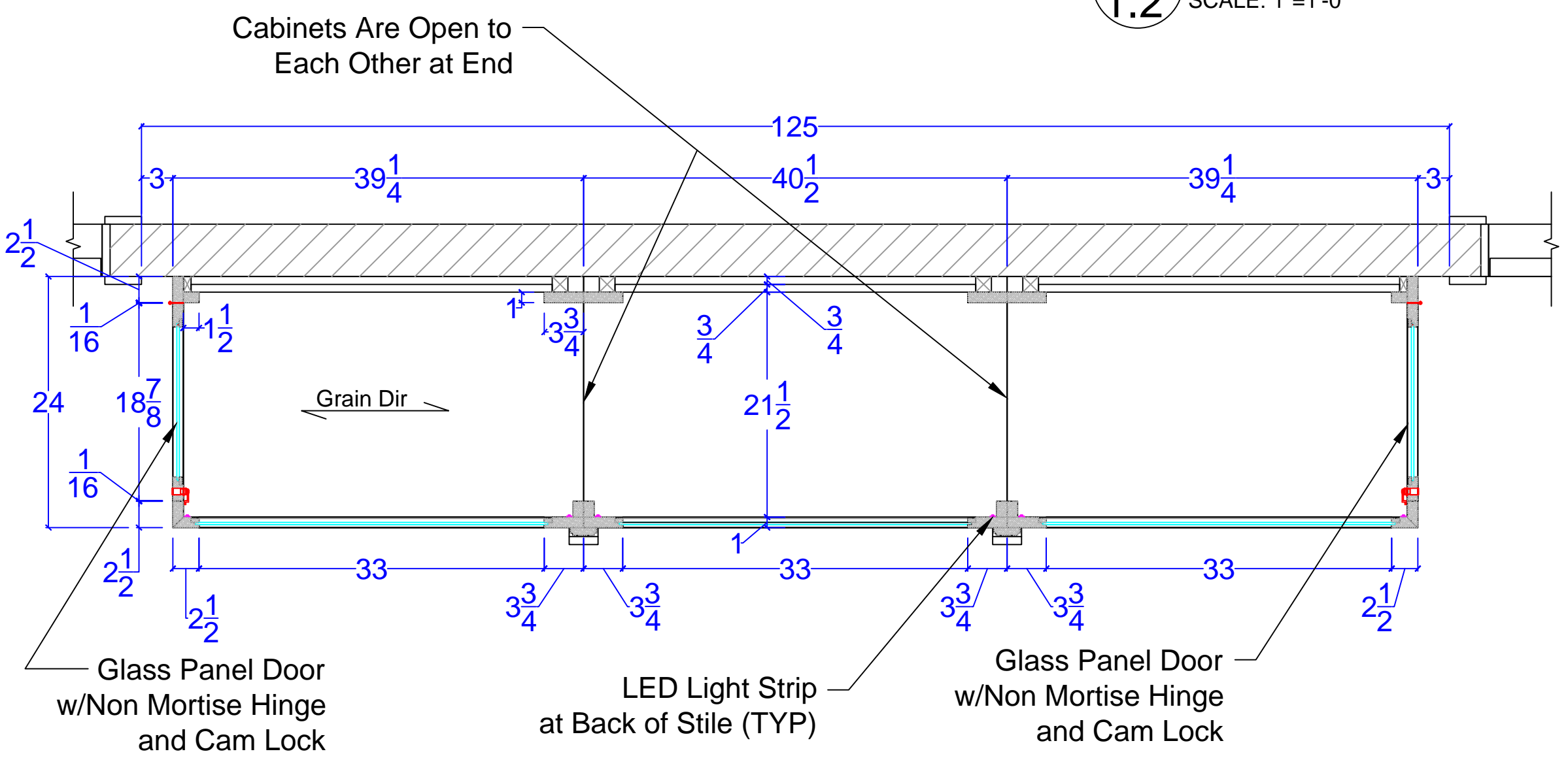

1 PLAN DETAIL
 1.2 SCALE: 1"=1'-0"

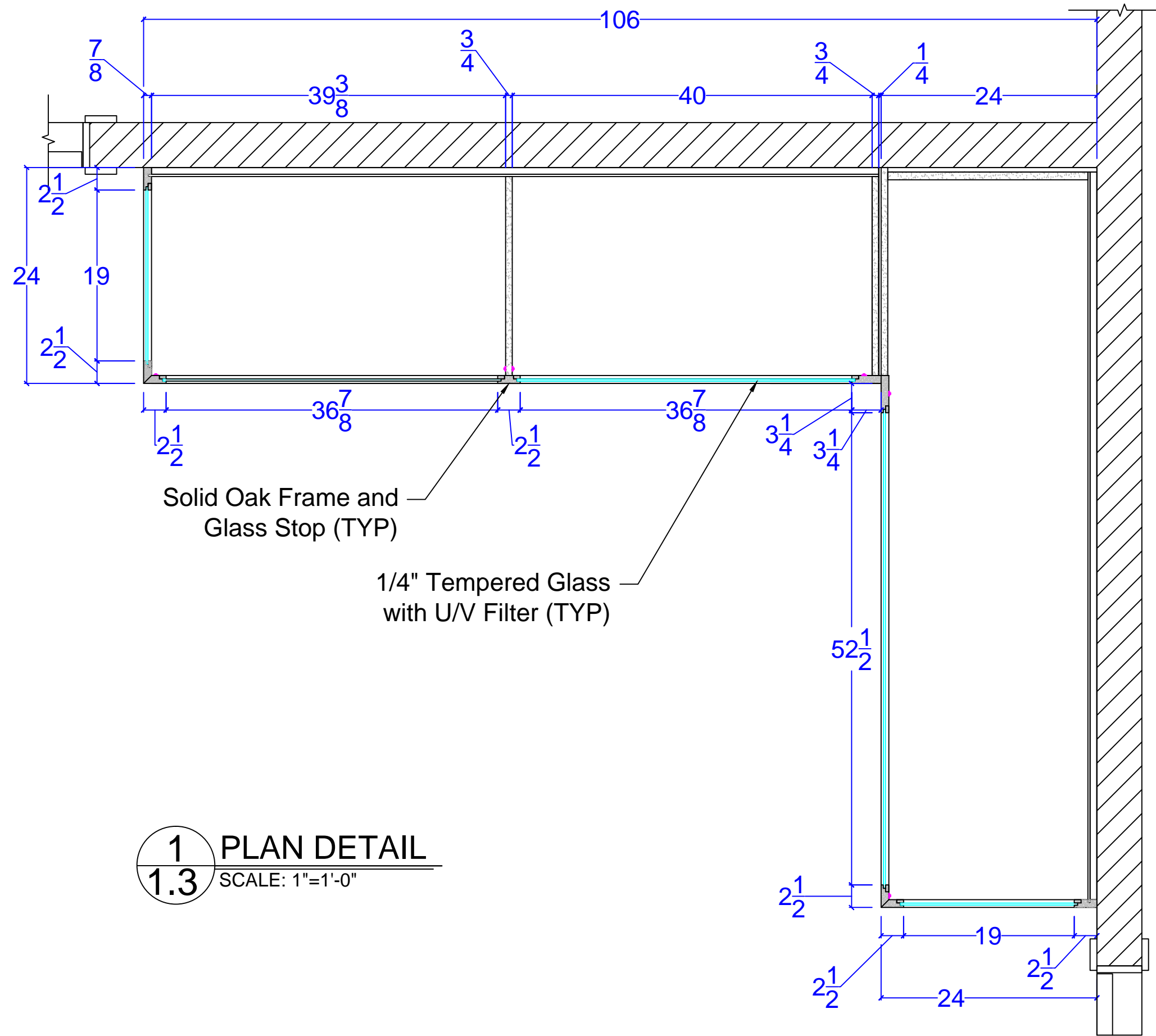

1 PLAN DETAIL
1.3 SCALE: 1"=1'-0"

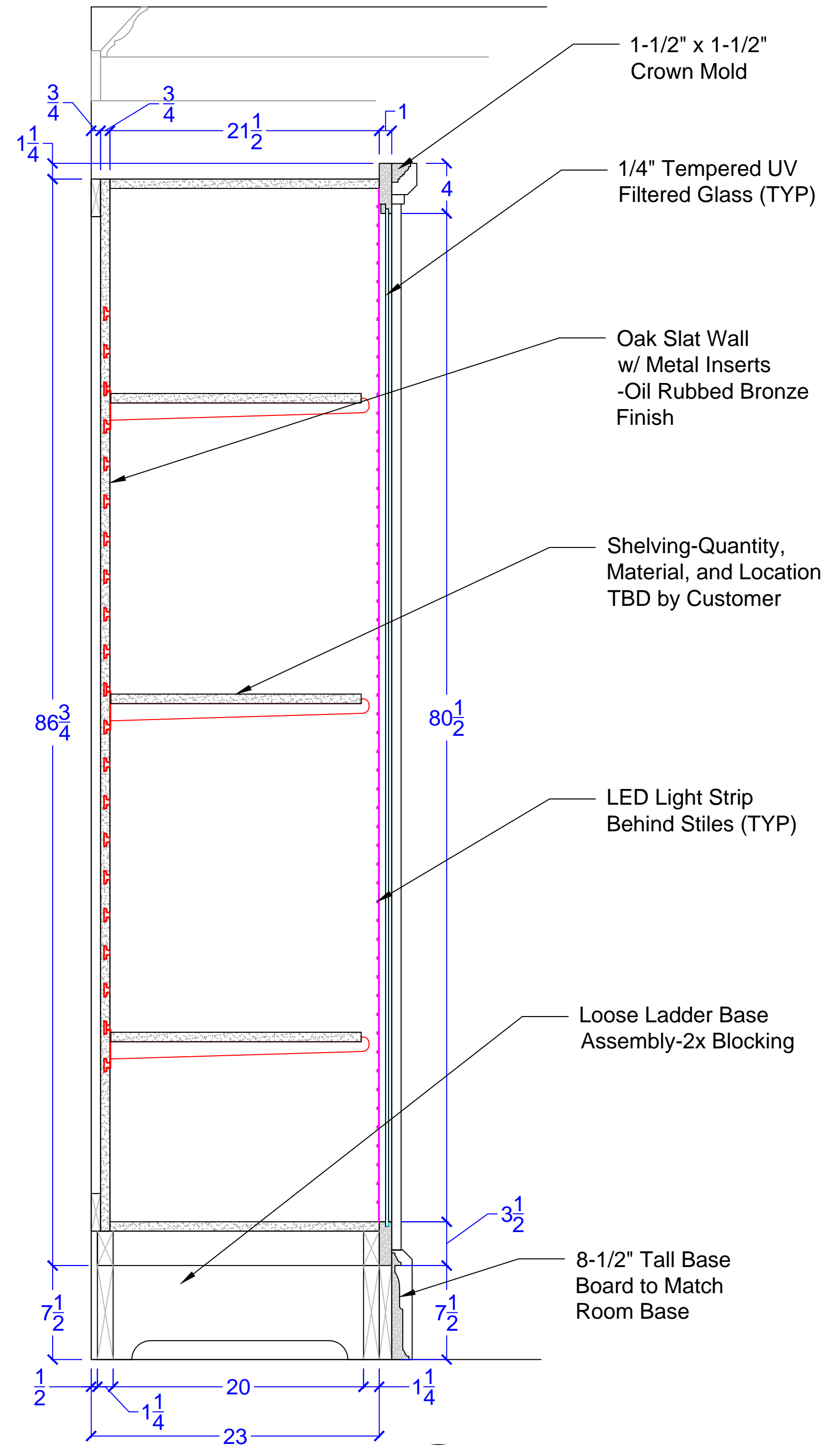

2 SECTION
1.3 SCALE: 1-1/2"=1'-0"

